

Note:

Version with trailer coupling:

Remove finisher strip.

Unfasten left/right expanding rivets and lift wheel arch finisher (1) to one side to remove.



Version with Park Distance Control (PDC):

Unfasten cable connector.

Unfasten connector, remove and expose the cable.



Unfasten inside left/ right nuts.

Tightening torque, refer to Technical Data 51 12 2AZ

Version without Park Distance Control (PDC):

Pull bumper backwards to remove.

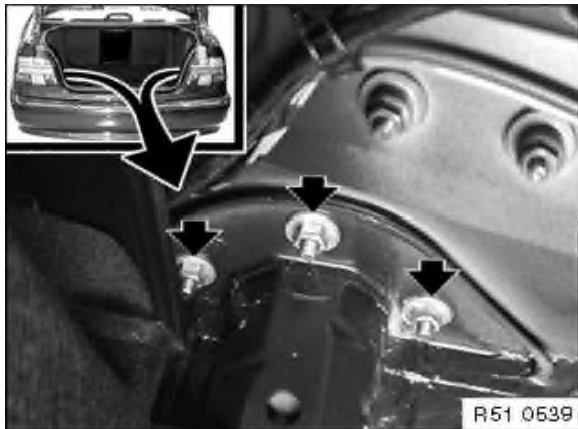



Version with Park Distance Control (PDC):

Pull bumper backwards slightly and remove cable grommet and cable.

Pull bumper backwards to remove.

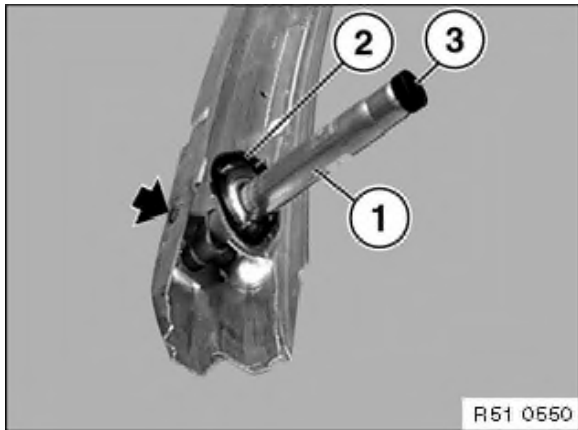

Installation:

Mount seal (2) on shock absorber (1)

Fit protective cap (3) to right shock absorber (1).

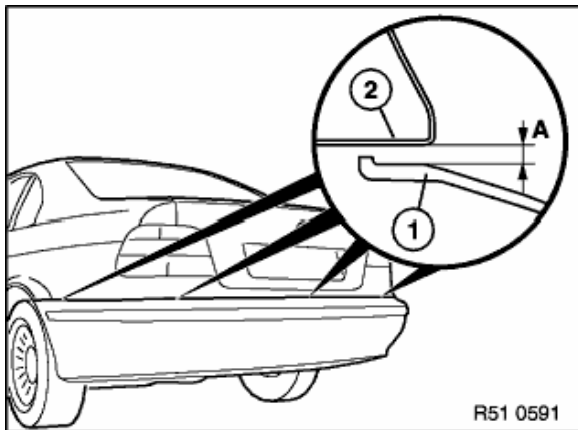

Ideal adjustment:

Gap (A) should be uniform down full length between bumper and aperture in body.

Dimension (A) = 5 ± 1 mm

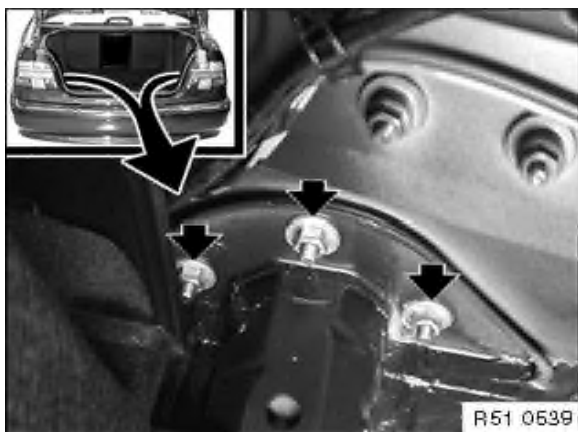

Loosen left/right inner nuts and adjust height of bumper.

For tightening torque, refer to Technical Data 51 12 2AZ